

KUKA



**The versatile robots
for the medium payload
category**

**KR 30-3,
KR 60-3**

»KR 30-3 AND KR 60-3: 20 VARIANTS FOR NEARLY EVERY REQUIREMENT

Stay flexible – it's easy with the KR 30-3 and KR 60-3: there are 28 variants for you to choose from, so you can rest assured that you will be able to deploy the right robot for almost every conceivable application in the medium payload category. The result, in every case, is an automation solution that is both efficient and cost-saving.

Put more precisely: with the KR 30-3 and KR 60-3, productivity gains of up to 30% are not uncommon – and an availability of nearly 100% is taken for granted. Further decisive advantages offered by these robots are their ease of operation and space-saving integration into existing production sequences. **The advantages: high planning reliability and security of investment.**

»EXTREMELY FAST – EXTREMELY PRECISE

Boost your production output: the optimally adapted motor/gear units of the KR 30-3 and KR 60-3 give you high performance in terms of cycle time and accuracy. The process forces generated are perfectly compensated for by the high stiffness of the FEM-optimized design. **The advantages: shorter cycle times and greater productivity.**

»EXTREMELY SPACE-SAVING – EXTREMELY EFFICIENT

Maximize your potential with the KR 30-3 and KR 60-3: the small footprint enables problem-free implementation even in confined cell layouts. And thanks to its minimal disruptive contours, these versatile all-rounders also guarantee efficient offline programming. **The advantages: high adaptability and simple programming.**

»TECHNICAL DETAILS KR 30-3 AND KR 60-3

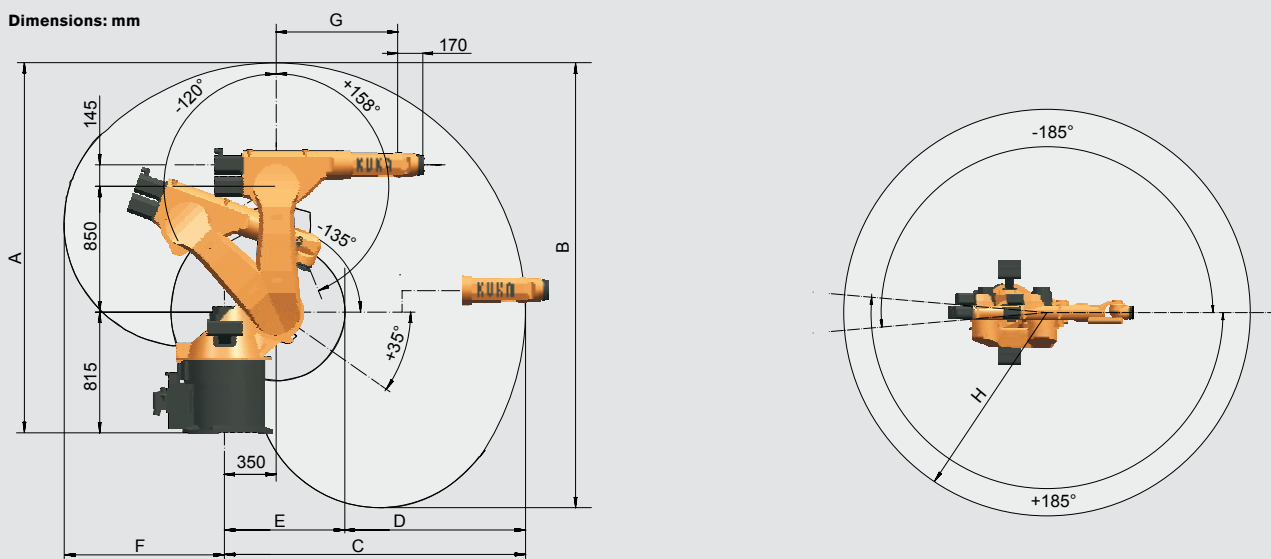

Work envelope	Dimensions ¹⁾							Volume
	A	B	C	D	E	F	G	
KR 30-3	2,498 mm	3,003 mm	2,033 mm	1,218 mm	815 mm	1,084 mm	820 mm	27.2 m ³
KR 60-3	2,498 mm	3,003 mm	2,033 mm	1,218 mm	815 mm	1,084 mm	820 mm	27.2 m ³
KR 60 L45-3	2,695 mm	3,398 mm	2,230 mm	1,362 mm	868 mm	1,283 mm	1,020 mm	36.9 m ³
KR 60 L30-3	2,984 mm	3,795 mm	2,429 mm	1,446 mm	983 mm	1,480 mm	1,220 mm	47.8 m ³

¹⁾ Relative to intersection of axes 4/5

»EXTREMELY DIVERSE - EXTREMELY OPTIMIZED

Bank on diversity: in addition to the KR 30-3, the KR 60-3 is available with two different arm extensions, substantially increasing the reach and radius of action. All models can be mounted on the floor or ceiling, as required by the application. For use in cleanrooms or environments with a high degree of fouling, the special variants Cleanroom (CR) and Foundry (F) are also available. **The advantages: greater flexibility and greater planning security.**

»EXTREMELY VERSATILE - EXTREMELY SAFE

KUKA offers you a comprehensive range of software: from ready-made application software for the most common applications to simulation programs for planning robot cells and Safe Robot Technology for monitoring safety zones. And for precisely coordinated teamwork with several robots, we offer the RoboTeam application package. **The advantages: maximum scope and maximum safety.**

Type	KR 30-3	KR 60-3	KR 60 L45-3	KR 60 L30-3
Maximum reach	2,033 mm	2,033 mm	2,230 mm	2,429 mm
Rated payload	30 kg	60 kg	45 kg	30 kg
Suppl. load, arm/link arm/rotating col.	35/0/0 kg			
Suppl. load, arm + link arm, max.	35 kg			
Maximum total load	65 kg	95 kg	80 kg	65 kg
Number of axes	6			
Mounting position	Floor, ceiling			
Variant	Cleanroom, Foundry			
Positioning repeatability*	±0.15 mm	±0.20 mm	±0.25 mm	±0.25 mm
Path repeatability*				
Controller	KR C2 edition2005			
Weight (excluding controller), approx.	665 kg	665 kg	671 kg	679 kg
Temperature during operation	+10 °C to +55 °C			
Protection classification	IP 65			
Robot footprint	850 mm x 950 mm			
Connection	7.3 kVA			
Noise level	< 75 dB			

Axis data	Range (software)	Speed with rated payload			
		30 kg	60 kg	45 kg	30 kg
Axis 1 (A1)	±185°	140°/s	128°/s	128°/s	128°/s
Axis 2 (A2)	+35°/-135°	126°/s	102°/s	102°/s	102°/s
Axis 3 (A3)	+158°/-120°	140°/s	128°/s	128°/s	128°/s
Axis 4 (A4)	±350°	260°/s	260°/s	260°/s	260°/s
Axis 5 (A5)	±119°	245°/s	245°/s	245°/s	245°/s
Axis 6 (A6)	±350°	322°/s	322°/s	322°/s	322°/s

Drive system, electromechanical with brushless AC servomotors

* to ISO 9283

Details provided about the properties and usability of the products are purely for information purposes and do not constitute a guarantee of these characteristics. The extent of goods delivered and services performed is determined by the subject matter of the specific contract. No liability accepted for errors or omissions.



»THE KUKA ROBOT GROUP: YOUR STRONG PARTNER

Quality made in Germany, creativity and the utmost commitment to customers and business partners: these form the basis on which KUKA develops the best possible technologies and thus the optimal automation concepts. The result is that you receive custom-tailored solutions and benefit from decisive process optimization.

Genuine passion for the fascination of robotics is reflected in our slogan “KUKA YOUR IDEAS”, which is also our promise to you: Whatever you want to do, and however unusual your idea may be, with us you can implement anything – irrespective of the specific branch of industry and irrespective of whether or not a similar application has existed before.

Whatever task you give us, KUKA has the required specialists. In close cooperation with experienced system partners with competence in their respective industries, we do everything in our power to implement your ideas. Let us work on them together.

»KUKA SERVICES: ALWAYS THERE FOR YOU

You can rely on us to stand by you in every phase of a project: from planning and commissioning to maintenance and conversion. 24 hours a day. 365 days a year. The high-density KUKA service network ensures that we are always in your vicinity and can start your production in record time.

KUKA YOUR IDEAS

KUKA ROBOTER GMBH

Global Sales Center
Hery-Park 3000
86368 Gersthofen
Germany
Tel. +49 821 4533-0
Fax +49 821 4533-1616
info@kuka-roboter.de

Additional contact addresses:
www.kuka-robotics.com